

Shuttle Flow Switch (Reed Type)

BW2 General Purpose Shuttle Flow Switch



General Description

The BW2 Series is a durable, general-purpose shuttle-type flow switch designed for reliable flow detection in high-volume lubrication, cooling and process systems. Featuring a straight-through flow path for minimal pressure drop, it is constructed from bronze or stainless steel for long service life in water or oil applications.

Key Features

Fixed Set Point: Pre-calibrated for precise flow detection.

High Accuracy: $\pm 1\%$ maximum deviation in set point repeatability.

Wide Flow Range: 0.5 to 100 GPM across multiple port sizes.

Robust Construction: Bronze or 316 stainless steel housing, Teflon® shuttle, 316 stainless steel spring.

Low Pressure Drop: Straight-through flow path design.

Broad Operating Temperature: -30°C to $+150^{\circ}\text{C}$

Application

- High-volume lubrication systems
- Cooling system flow monitoring
- Industrial process flow detection
- Pump protection
- HVAC and water treatment
- Oil circulation systems

Environmental & Mechanical Specifications

Item	Specification
Housing Material	Bronze or 316 Stainless Steel
Shuttle Material	Teflon
Bonnet Material	Bronze or Stainless Steel
Spring Material	316 Stainless Steel
Max Operating Pressure	400 PSIG (27.6 bar) @ 38°C
Proof Pressure	800 PSIG (55.2 bar) @ 38°C
Operating Temperature	-30°C to +150°C
Set Point Accuracy	±1% maximum deviation
Set Point Differential	15% maximum
Repeatability	1% maximum
Filtration Recommendation	150 micron filter recommended
Minimum Line Pressure	5 PSI required

Electrical Specifications

Item	Specification
Switch Type	SPDT (Single-Pole Double-Throw)
Switch Configuration	Form C (SPDT) – NC, Common, NO
Electrical Rating	20 VA
Electrical Termination	No. 18 AWG polymeric lead wires, 24" length
Wire Colors	Red (NC), Black (Common), Orange (NO)

Important Notes:

- 1, Flow settings are calibrated with water at +20°C in horizontal orientation (leads up).
- 2, Viscosity changes will affect setpoints (typically decreases with higher viscosity).
- 3, A 150-micron filter is recommended for extended service life.
- 4, Consult factory for fluids other than water or special calibration requirements.

Part Number Naming

BW2 – XXX – X – X

Code	Description
BW2	Shuttle Series
XXX	Flow Setting
X	Housing Material: B=Brass/ S=Stainless Steel/ P=Plastic
X	Contact Form: A = NO / B = NC / C = Changeover
XXX	Additional customize information

Part Number	Flow Setting (GPM)	Housing Material	Port Size
BW2-005-B-A	0.5	Bronze	1" NPT
BW2-005-S-A	0.5	Stainless Steel	1" NPT
BW2-010-B-A	1	Bronze	1" NPT
BW2-010-S-A	1	Stainless Steel	1" NPT
BW2-020-B-A	2	Bronze	1" NPT
BW2-005-S-A	2	Stainless Steel	1" NPT
BW2-015-B-A	1.5	Bronze	1½" NPT
BW2-030-B-A	3	Bronze	1½" NPT
BW2-020-B-A	2	Bronze	2" NPT
BW2-020-S-A	2	Stainless Steel	2" NPT
BW2-040-B-A	4	Bronze	2" NPT
BW2-040-B-A	4	Stainless Steel	2" NPT

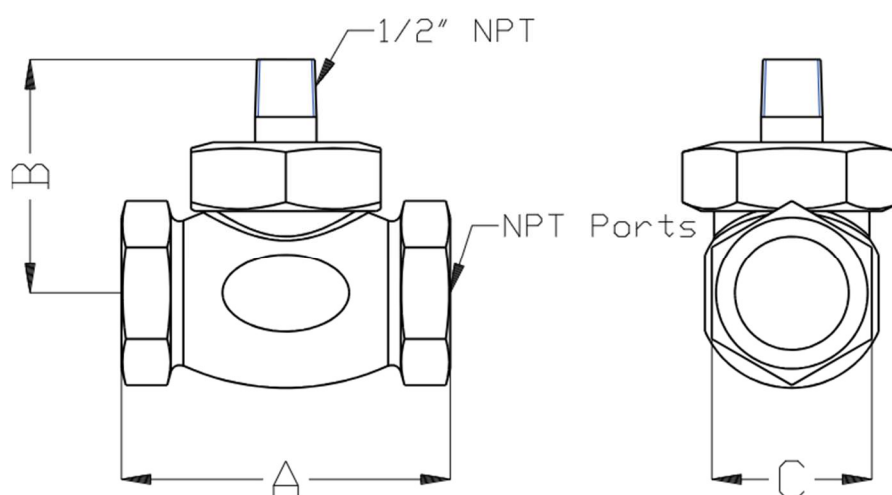

Port Size NPT	A(Inch)	B(Inch)	C(Inch)
1" NPT	3.25	3	1.781
1½" NPT	4.5	3.5	2.5
2" NPT	5.375	4	3.094